

Globe Valve

Pressure Rating: PN 10
 Face to Face: DIN EN 558-1 Series 1
 Material of Construction: Ductile Cast Iron GGG 40/50



DN 20 - DN 300

Catalogue No: 11-2010110

Range of application: Water, steam				
Size DN	Pressure rating PN	Hydrost. test pressure in bar		Admissible working pressure in bar up to 70°C
		Body	Seat	
20 - 300	10	15	10	10

In case of order please specify the working conditions

Other working temperatures possible on request



Materials / Equipment	
Catalogue No.	11-2010110
Body	GGG 40/50
Cover	GGG 40/50
Cone	GGG 40/50
Body seating	Bronze
Stem	Stainless steel 1.4021
Nut	Bronze
Stuffingbox gland	GGG 40-50
Stuffingbox packing	PTFE
Cone seat	Bronze
Stem nut	Bronze
Corrosion protection	Epoxy powder coated RAL 5015
Handwheel	GGG 40-50

Size	Face to face length acc. to DIN EN 558-1	Flange Ø	Handwheel Ø	Dimensions		Weight ~ kg
				h ₁ mm	h ₂ mm	
DN mm	L mm	D mm	D ₁ mm	h ₁ mm	h ₂ mm	~ kg
20	150	105	100	180	8	4
25	160	115	120	189	10	5
32	180	140	120	189	13	7
40	200	150	140	229	16	9
50	230	165	140	229	20	11
65	290	185	160	261	26	15
80	310	200	180	294	32	22
100	350	220	200	344	40	31
125	400	250	250	373	40	45
150	480	285	320	448	60	64
200	600	340	400	532	80	106
250	730	395	400	642	100	170
300	850	445	400	709	120	238

We reserve the right to make technical modifications

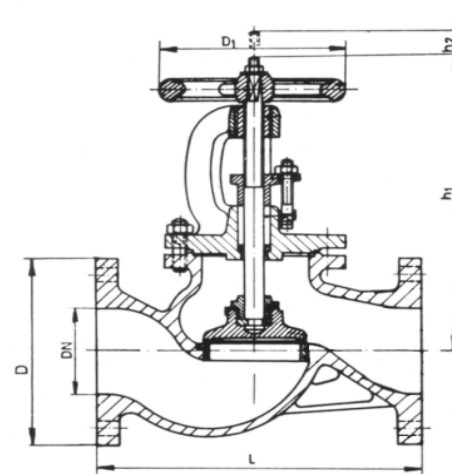

SAUDI VALVES MANUFACTURING

Tel.: +966 3 341 8514 - Fax: +966 3 341 8515
 P. O. Box 10137 Jubail Industrial City, 31961 The Kingdom of Saudi Arabia
 E-mail: info@saudivalves.com - Internet: www.saudivalves.com

ISO 9001

BUREAU VERITAS
 Certification



20.03.2009

N° 215125