

# Gate Valve

Acc. to DIN EN 1171  
 Metal Seated  
 Face to Face: DIN 3202-1  
 Pressure Rating: PN 10  
 Material of Construction: Ductile Cast Iron GGG 40/50



**DN 40 - DN 1000**

**Catalogue No: 02-2011510**

Range of application: Potable water and waste water				
Size DN	Pressure rating PN	Hydrostest pressure in bar		Admissible working pressure in bar up to 70°C
		Body	Seat	
40 - 1000	10	15	10	10

*In case of order please specify the working conditions*

*Other working temperatures possible on request*

Materials / Equipment	
<b>Catalogue No.</b>	<b>02-2011510</b>
Body	GGG 40/50
Bonnet	GGG 40/50
Wedge	GGG 40/50
Seatings in the body	Gunmetal
Seatings on the wedge	Gunmetal
Stem	Stainless steel 1.4021
Stem nut	Gunmetal
Stem guide bush	Gunmetal
O-rings	EPDM or NBR
Bolts and nuts	Stainless steel A2
Corrosion protection	Epoxy powder coated RAL 5015
Handwheel	Steel, black coated



Size	Face to face length acc. to DIN 3202-1 F15	Flange Ø	Dimensions		Weight kg	Volume m³
			H mm	d mm		
DN mm	L mm	D mm	H mm	d mm	kg	m³
40	240	150	280	200	21	0.01
50	250	165	290	225	27	0.02
65	270	185	330	280	40	0.03
80	280	200	350	280	45	0.40
100	330	220	400	320	68	0.50
125	360	250	460	360	90	0.60
150	390	285	520	360	120	0.90
200	460	340	630	400	190	0.16
250	530	395	730	500	222	0.22
300	630	445	840	640	370	0.30
350	690	505	940	640	467	0.33
400	750	565	1070	720	650	0.55
500	880	670	1260	800	1,123	0.80
600	1000	780	1480	800	1,685	1.20
700	1130	895	1620	800	2,250	1.70
800	1250	1015	1820	900	3,195	2.40
900	1380	1115	2040	900	4,200	3.20
1000	1500	1230	2200	900	5,000	4.20

*We reserve the right to make technical modifications*

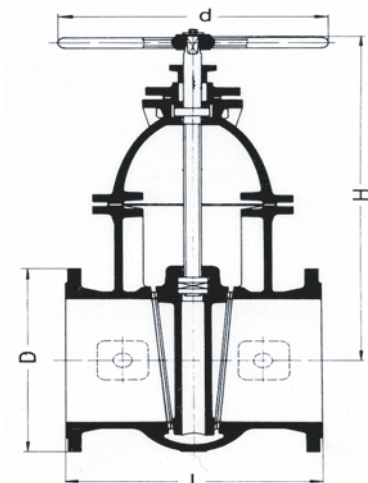

## SAUDI VALVES MANUFACTURING

Tel.: +966 3 341 8514 - Fax: +966 3 341 8515

P. O. Box 10137 Jubail Industrial City, 31961 The Kingdom of Saudi Arabia

E-mail: [info@saudivalves.com](mailto:info@saudivalves.com) - Internet: [www.saudivalves.com](http://www.saudivalves.com)



20.03.2009